

**THIS SPACE FOR DESIGNER/ENGINEER APPROVAL**

Job/Customer _____	Date _____	Contractor _____
Model Specified _____	Qty _____	Approved By _____
Designer/Engineer _____	Date _____	Contractor's PO# _____
Submitted by _____	Date _____	Other _____

# 8141 Series

**Full Port Forged Brass Uni-Flange Ball Valve  
w/ Detachable Rotating Flange, Multi-Function Drain,  
Adjustable Packing Gland, Nuts & Bolts  
Press x Rotating Flange  
250 PSI/250°F Max  
ISO 9001**



Item #	Size	CTN/CASE	A	B	C	D	E	F	G	H
81413HV	3/4"	1/20	3/4	3 11/16	2 1/4	2 3/8	3/8	3 3/16	1 9/16	2 3/4
81414HV	1"	1/20	1	3 7/8	2 5/8	2 3/8	3/8	3 3/16	1 9/16	2 13/16
81415HV	1 1/4"	1/10	1 1/4	4 7/16	2 15/16	3 3/8	3/8	3 3/16	1 3/4	3 5/16
81416HV	1 1/2"	1/10	1 7/16	5	3 3/16	3 3/8	3/8	3 3/16	1 3/4	3 1/2
81417HV	2"	1/10	1 15/16	5 13/16	3 9/16	3 3/8	3/8	3 11/16	1 3/4	3 3/4



**PATENTED TECHNOLOGY**

TEMP °F	PSI
100	250
150	250
200	250
250	250
300	N/A
350	N/A
366	N/A

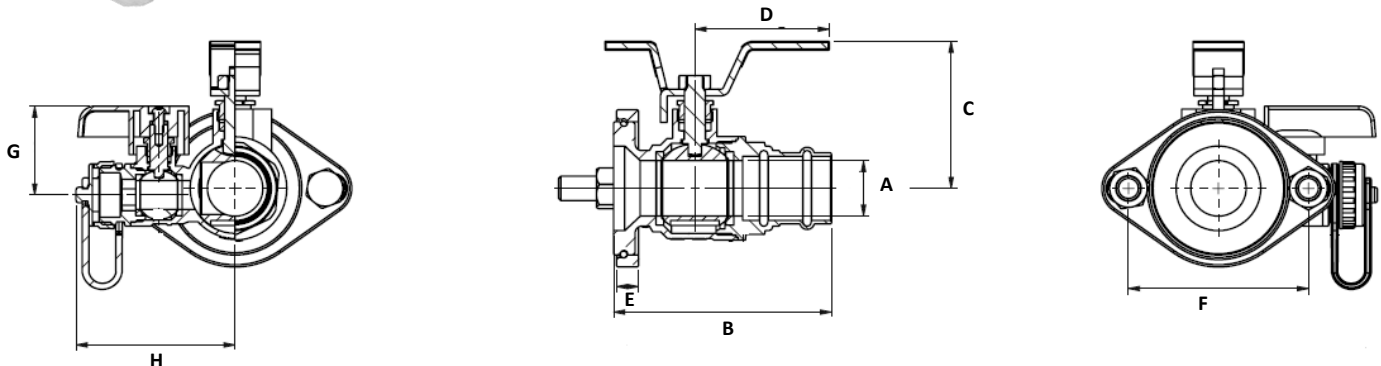

**Specifications:** Designed for residential, commercial or industrial use with water only. This approved Webstone valve is actuated by a blowout proof stem and features an adjustable packing gland. HV models fit both standard and high velocity pumps.



Quality and Commitment Since 1954

www.webstonevalves.com · P: (800) 225-9529 · F: (800) 336-5133

Webstone product specifications in U.S. customary units are approximate and are provided for reference only. Webstone reserves the right to change or modify product design, construction, specifications or materials without prior notice and without incurring any obligation to make such changes and modifications on Webstone products previously or subsequently sold.

**THIS SPACE FOR DESIGNER/ENGINEER APPROVAL**

Job/Customer _____	Date _____	Contractor _____
Model Specified _____	Qty _____	Approved By _____
Designer/Engineer _____	Date _____	Contractor's PO# _____
Submitted by _____	Date _____	Other _____

NO.	DESCRIPTION	MATERIAL
1	Body	Brass
2	Seat	PTFE
3	Stem	Brass
4	Stem Seal	PTFE
5	Ball	Brass
6	End Cap	Brass
7	Handle	Plated Steel
8	Packing Gland	Brass
9	Drain Seats	PTFE
10	Drain Ball	Plated Brass
11	Drain Stem	Brass
12	Drain End Cap	Brass
13	Drain Handle	Epoxy Coated Aluminum
14	Stem Seal	PTFE
15	Packing Gland	Brass
16	Handle Nut	Stainless Steel
17	Retainer	Stainless Steel
18	Flange	Brass
19	Screw	Stainless Steel
20	Gasket	EPDM
21	Cap	Brass
22	Washer	Stainless Steel
23	Strap	PVC
24	Flange Bolts	Stainless Steel
25	Hex nuts	Stainless Steel

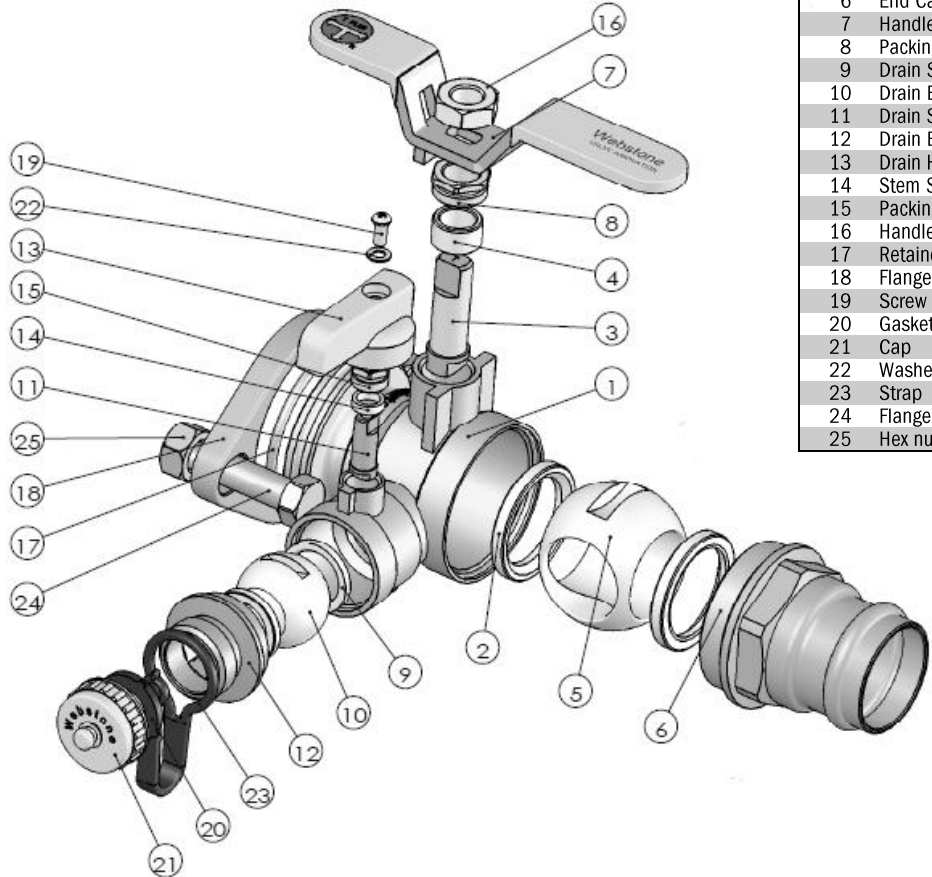

Quality and Commitment Since 1954

www.webstonevalves.com · P: (800) 225-9529 · F: (800) 336-5133

Webstone product specifications in U.S. customary units are approximate and are provided for reference only. Webstone reserves the right to change or modify product design, construction, specifications or materials without prior notice and without incurring any obligation to make such changes and modifications on Webstone products previously or subsequently sold.